

12 11 10 9 8 7 6 5 4 3 2 1

H

G

F

E

D

C

B

A

H

G

F

E

D

C

B

A

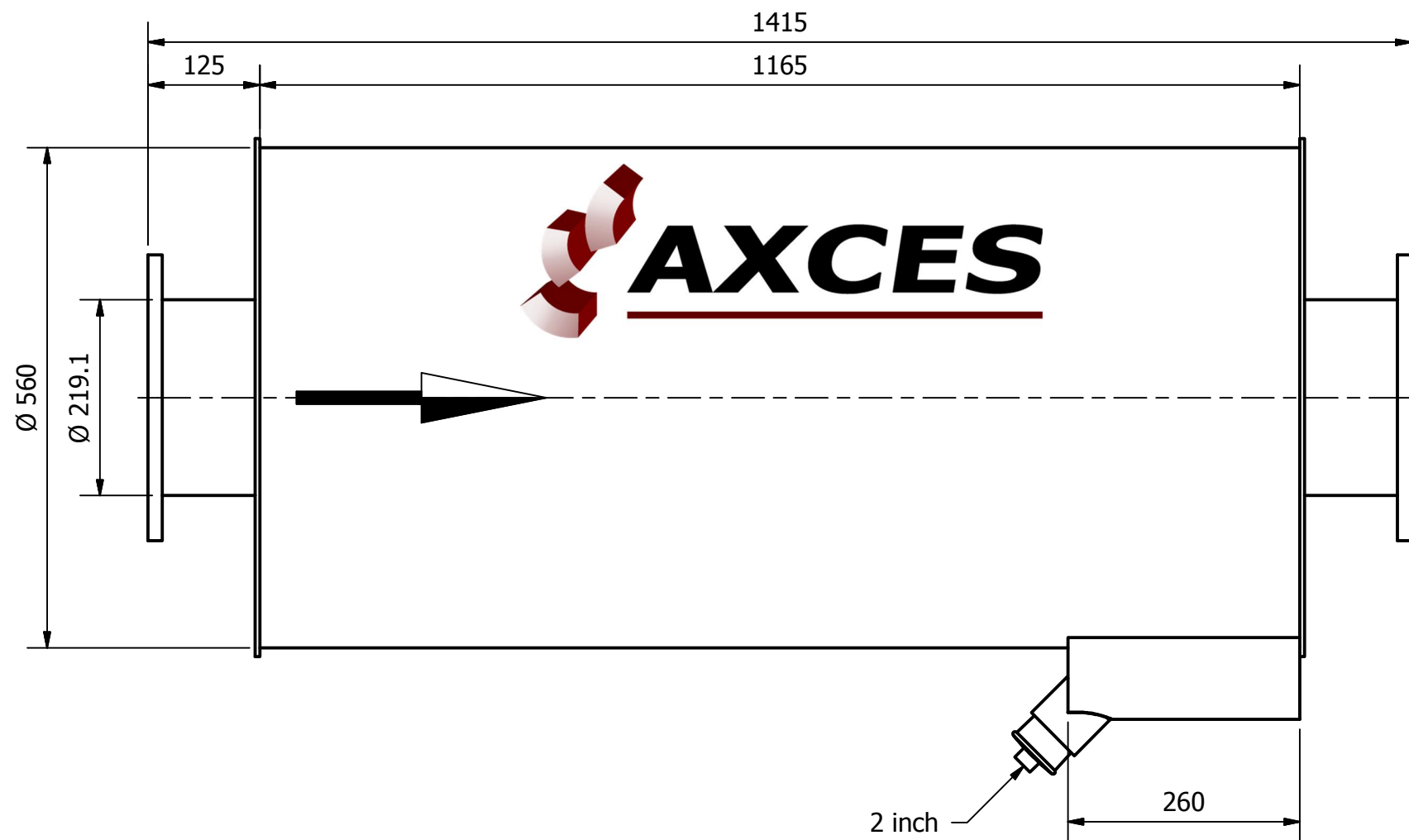
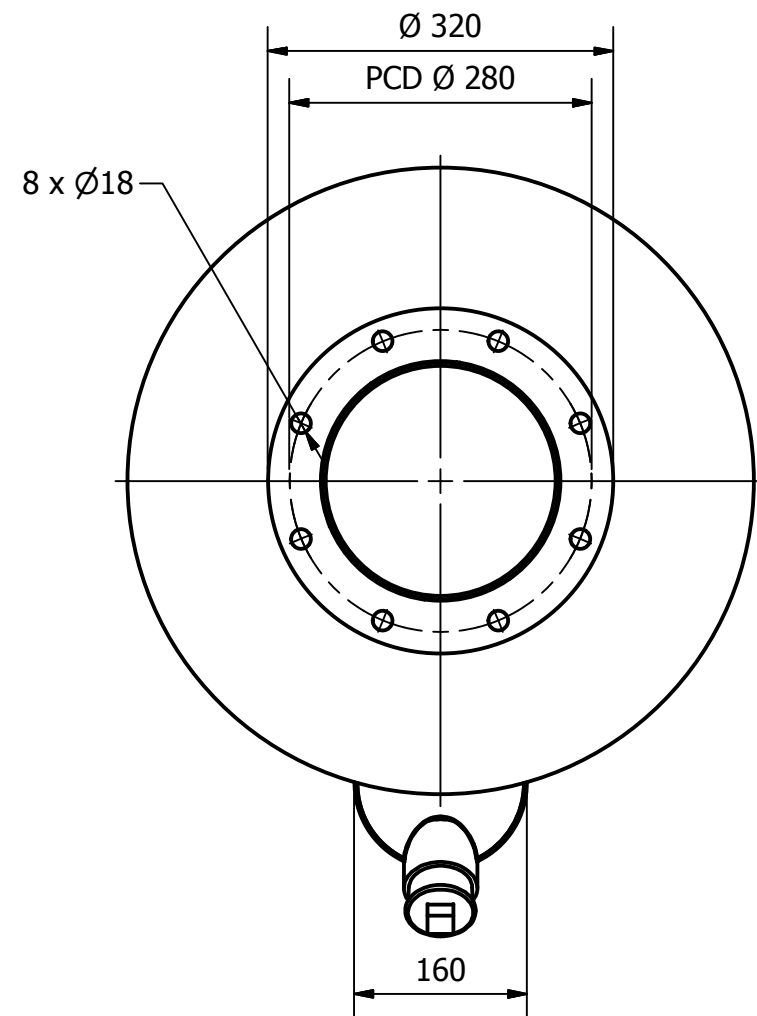

MATERIAL MILD STEEL S235JR												
FLANGES DIN 2573 PN6				MOD		DESCRIPTION		DRAWN		DATE		
COATING SILICONE PAINT - THERMORESISTANT UP TO 600C, SILVER						Axces B.V. Ondernemersweg 12 4691 SL Tholen The Netherlands www.axces.com +31 (0) 166 603 285		ALL RIGHTS RESERVED THIS DRAWING SHALL NOT BE REPRODUCED WITHOUT THE PRIOR PERMISSION OF AXCES B.V.		DATE		
WELDING QUALITY ACC. TO 5817 CLASS C								1		2013-11-11		
TOLERANCES ACC. TO EN-ISO 13920 CLASS B,F								ARTICLE NUMBER		121000000080		
DIMENSIONS		LENGTH	ANGLE	STRAIGHTNESS FLATNESS PARALLELSM	TITLE EXHAUST SPARK ARRESTOR		DRAWING NUMBER 181113/CP18/8		DRAWN ES			
400 mm		+/-2 mm	+/-45'	+/-1,5 mm	TYPE CP18-8" (NB200)		SPARK ARRESTOR BUILT-IN		DAMPING 18 db(A)			
1000 mm		+/-3 mm	+/-30'	+/-3 mm	PROJECTION 		WEIGHT 103 Kg		SCALE 1 / 7		FORMAT A3	
2000 mm		+/-4 mm	+/-20'	+/-4,5 mm								
4000 mm		+/-6 mm	+/-20'	+/-6 mm								
>4000 mm		+/-8 mm	+/-20'	+/-8 mm								

12 11 10 9 8 7 6 5 4 3 2 1