

1 2 3 4 5 6 7 8 9 10 11 12

A

A

B

B

C

C

D

D

E

E

F

F

G

G

H

H

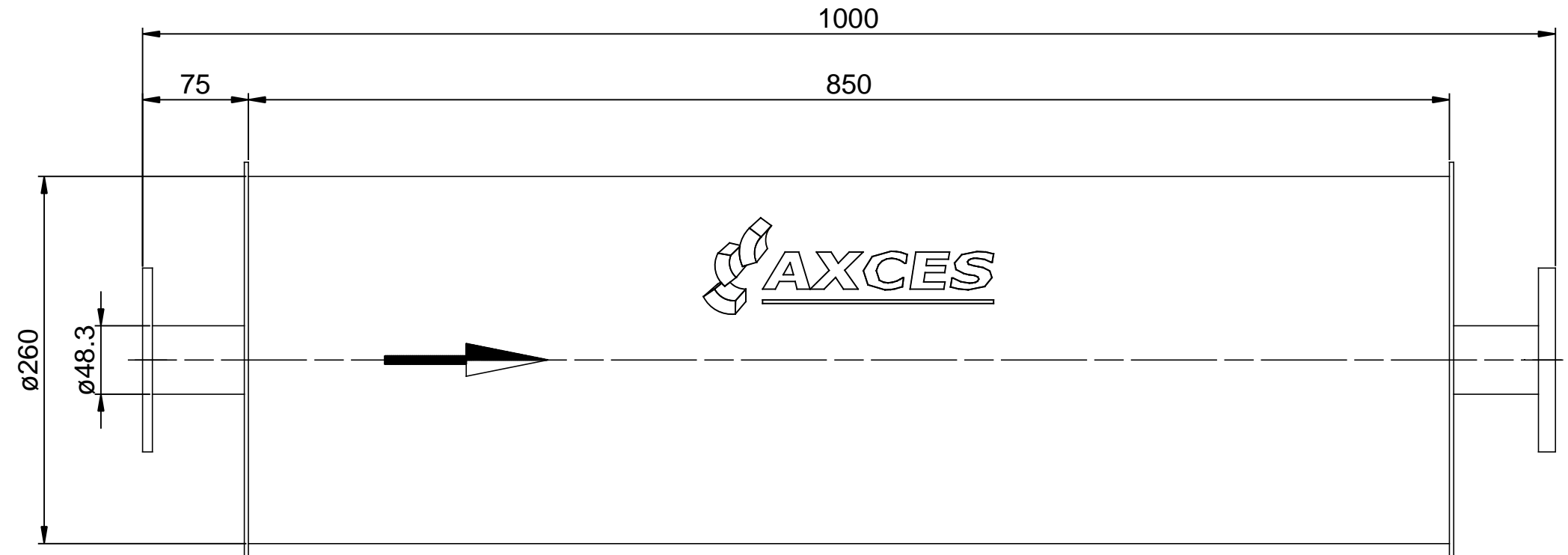
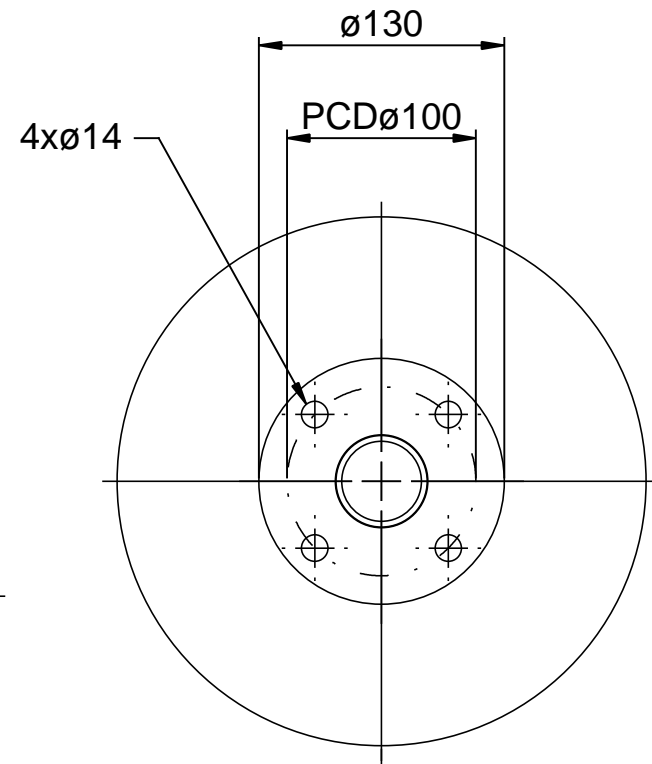

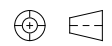
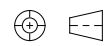
MATERIAL				B	---	-	-
MILD STEEL S235JR				A	---	-	-
FLANGES				MOD	DESCRIPTION	DRAWN	DATE
DIN 2573 PN 6						ALL RIGHTS RESERVED THIS DRAWING SHALL NOT BE REPRODUCED WITHOUT THE PRIOR PERMISSION OF AXCES B.V.	
COATING						AXCES B.V. Ondernemersweg 12 4691 SL Tholen The Netherlands www.axces.com +31 (0) 166 603 285	
SILICONE PAINT				TITLE <b>EXHAUST SILENCER</b>		DRAWING NUMBER <b>170715/REAB45/1,5</b>	
THERMORESISTANT UP TO 600°C, SILVER						TYPE <b>REAB45-1,5" (NB 40)</b>	
WELDING QUALITY ACC. TO EN-ISO 5817 CLASS C				PROJECTION 		DAMPING <b>45 dB(A)</b>	
TOLERANCES ACC. TO EN-ISO 13920 CLASS B,F						WEIGHT <b>30 Kg</b>	
DIMENSIONS	LENGTH	ANGLE	STRAIGHTNESS FLATNESS PARALLELISM	DRAWING NUMBER <b>170715/REAB45/1,5</b>		SCALE	FORMAT
400 mm	± 2 mm	± 45'	± 1,5 mm	TYPE <b>REAB45-1,5" (NB 40)</b>		1 / 4	A3
1000 mm	± 3 mm	± 30'	± 3 mm	PROJECTION 			
2000 mm	± 4 mm	± 20'	± 4,5 mm	WEIGHT <b>30 Kg</b>			
4000 mm	± 6 mm	± 20'	± 6 mm	DRAWING NUMBER <b>170715/REAB45/1,5</b>			
>4000 mm	± 8 mm	± 20'	± 8 mm	TYPE <b>REAB45-1,5" (NB 40)</b>			

1 2 3 4 5 6 7 8 9 10 11 12