

1 2 3 4 5 6 7 8 9 10 11 12

A

A

B

B

C

C

D

D

E

E

F

F

G

G

H

H

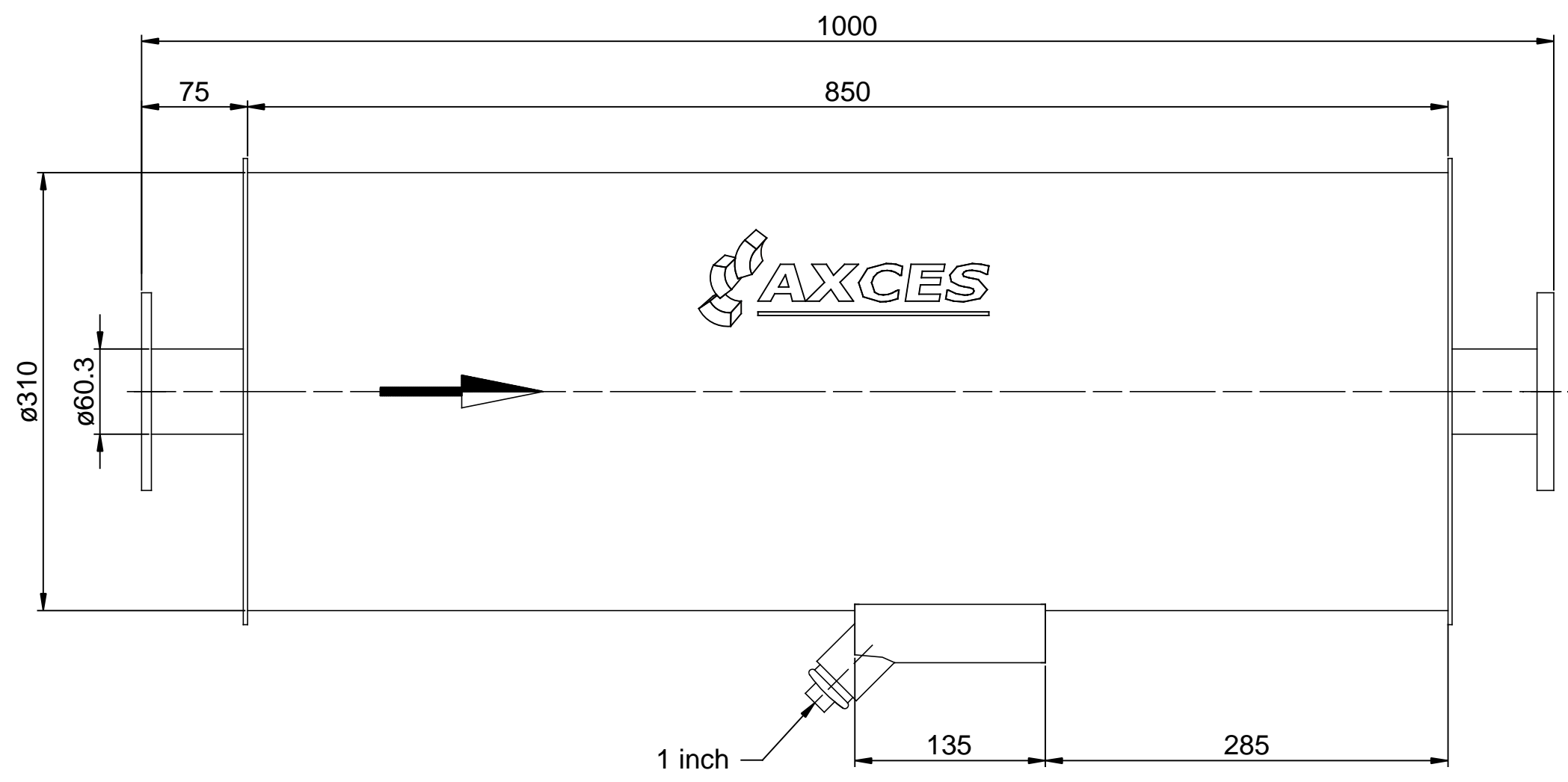
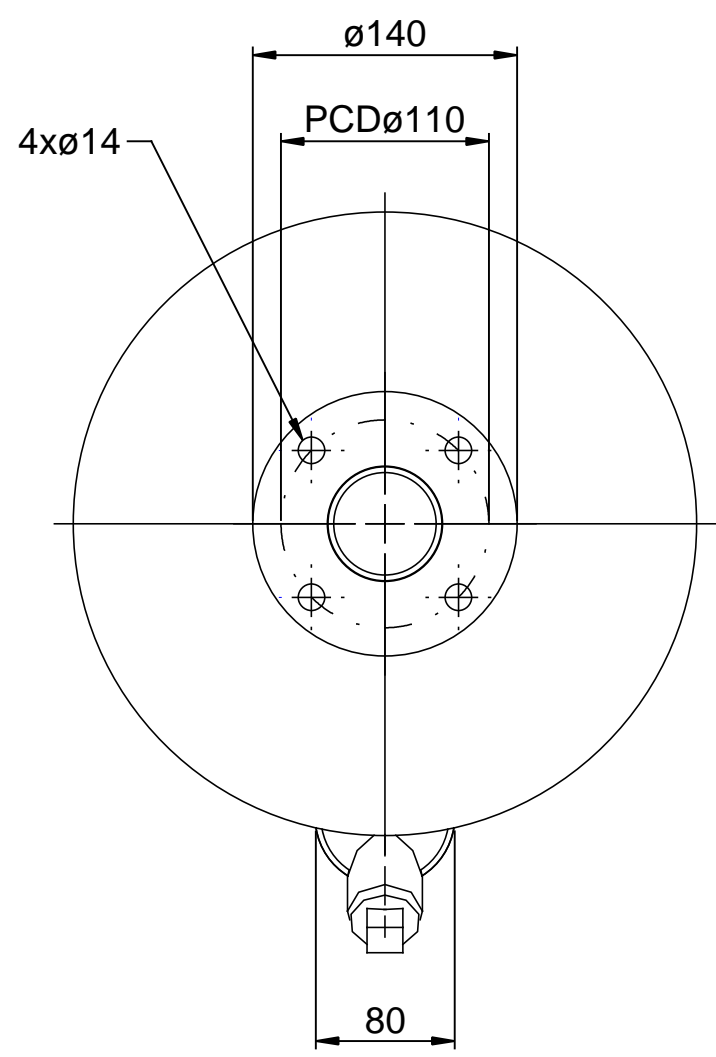

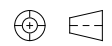
MATERIAL				B	---	-	-
MILD STEEL S235JR				A	---	-	-
FLANGES				MOD	DESCRIPTION	DRAWN	DATE
DIN 2573 PN 6						ALL RIGHTS RESERVED THIS DRAWING SHALL NOT BE REPRODUCED WITHOUT THE PRIOR PERMISSION OF AXCES B.V.	
COATING						AXCES B.V. Ondernemersweg 12 4691 SL Tholen The Netherlands www.axces.com +31 (0) 166 603 285	
SILICONE PAINT				TITLE EXHAUST SILENCER		DRAWING NUMBER 170715/REAB45-IS/2	
THERMORESISTANT UP TO 600°C, SILVER						TYPE REAB45-IS-2" (NB 50)	
WELDING QUALITY ACC. TO EN-ISO 5817 CLASS C				PROJECTION 		DAMPING 45 dB(A)	
TOLERANCES ACC. TO EN-ISO 13920 CLASS B,F						WEIGHT 36 Kg	
DIMENSIONS	LENGTH	ANGLE	STRAIGHTNESS FLATNESS PARALLELISM	DRAWING NUMBER 170715/REAB45-IS/2		SCALE 1 / 4	
400 mm	± 2 mm	± 45'	± 1,5 mm	TYPE BUILT-IN		FORMAT A3	
1000 mm	± 3 mm	± 30'	± 3 mm	WEIGHT 36 Kg		SCALE 1 / 4	
2000 mm	± 4 mm	± 20'	± 4,5 mm	DRAWING NUMBER 170715/REAB45-IS/2		SCALE 1 / 4	
4000 mm	± 6 mm	± 20'	± 6 mm	TYPE BUILT-IN		SCALE 1 / 4	
>4000 mm	± 8 mm	± 20'	± 8 mm	WEIGHT 36 Kg		SCALE 1 / 4	

1 2 3 4 5 6 7 8 9 10 11 12