

1 2 3 4 5 6 7 8 9 10 11 12

A

A

B

B

C

C

D

D

E

E

F

F

G

G

H

H

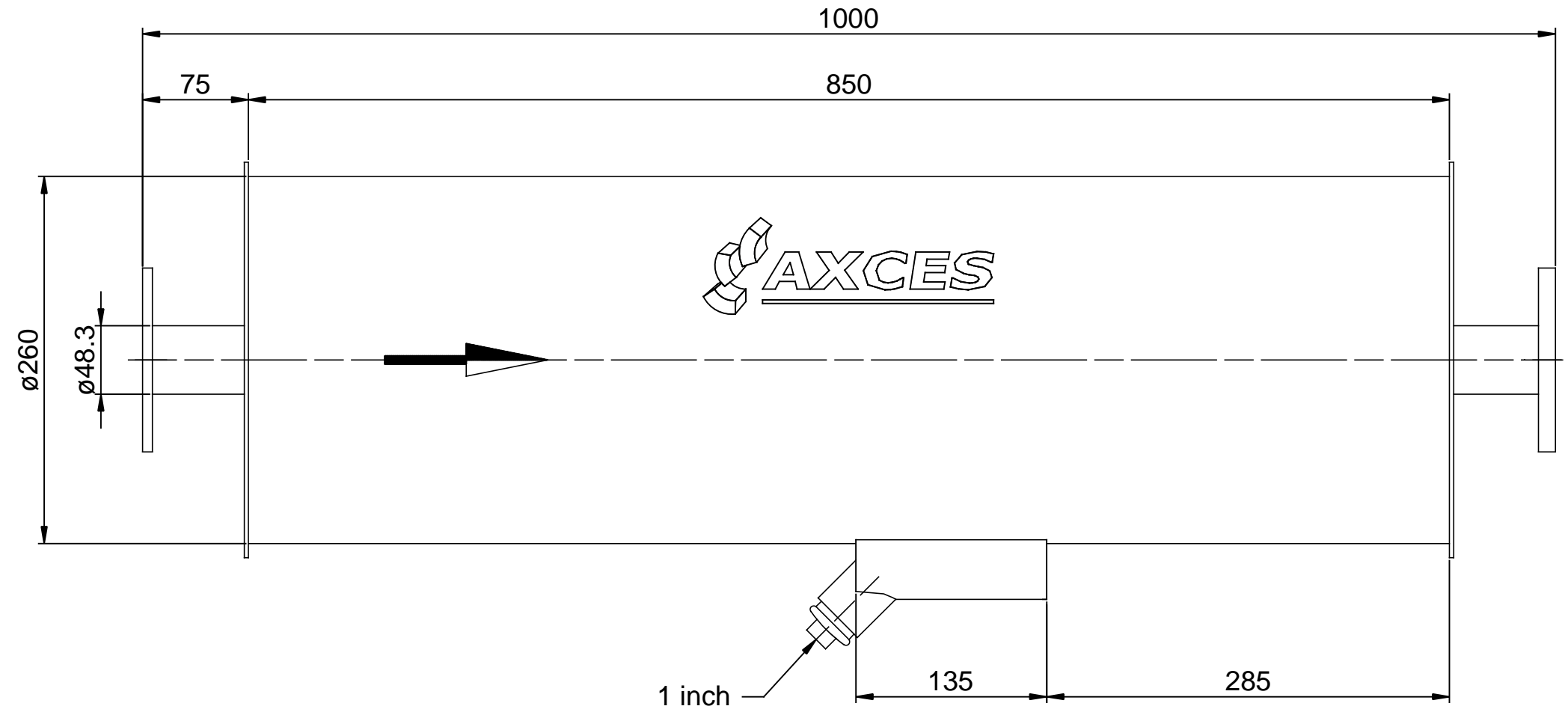
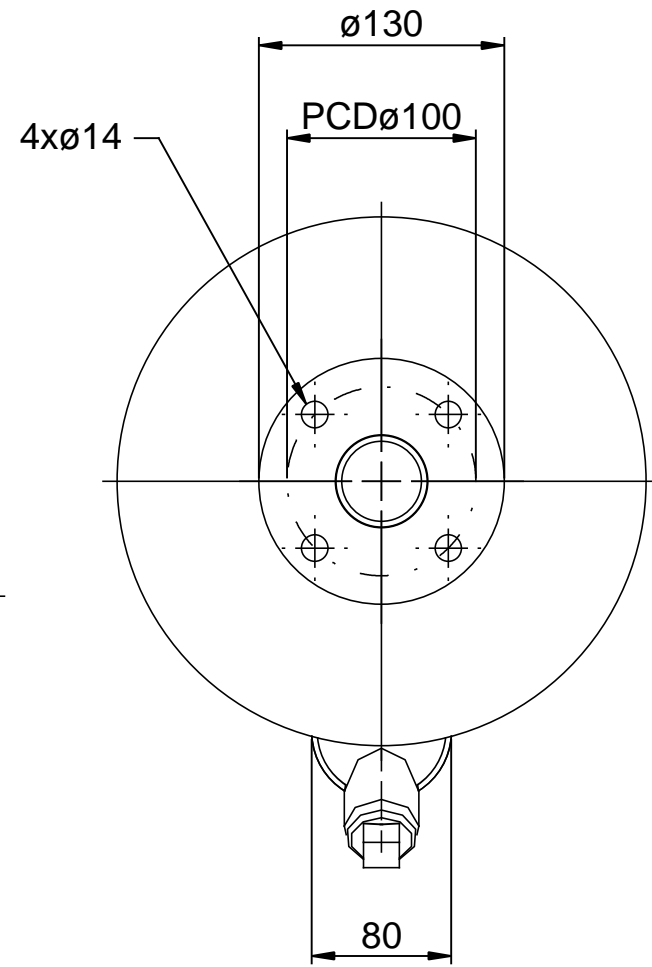

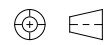
MATERIAL				B	---	-	-
MILD STEEL S235JR				A	---	-	-
FLANGES				MOD	DESCRIPTION	DRAWN	DATE
DIN 2573 PN 6						AXCES B.V. Ondernemersweg 12 4691 SL Tholen The Netherlands www.axces.com +31 (0) 166 603 285	
COATING							
SILICONE PAINT				ALL RIGHTS RESERVED THIS DRAWING SHALL NOT BE REPRODUCED WITHOUT THE PRIOR PERMISSION OF AXCES B.V.		NUMBER OF SHEETS	DATE
THERMORESISTANT UP TO 600°C, SILVER				WELDING QUALITY ACC. TO EN-ISO 5817 CLASS C		1	2015-07-17
TOLERANCES ACC. TO EN-ISO 13920 CLASS B,F				TITLE EXHAUST SILENCER		ARTICLE NUMBER	
DIMENSIONS	LENGTH	ANGLE	STRAIGHTNESS FLATNESS PARALLELISM	DRAWING NUMBER 170715/REAB45-IS/1,5		DRAWN KH	
400 mm	± 2 mm	± 45'	± 1,5 mm	TYPE REAB45-IS-1,5" (NB 40)		DAMPING 45 dB(A)	
1000 mm	± 3 mm	± 30'	± 3 mm	PROJECTION 		SCALE 1 / 4	
2000 mm	± 4 mm	± 20'	± 4,5 mm	WEIGHT 30 Kg		FORMAT A3	
4000 mm	± 6 mm	± 20'	± 6 mm				
>4000 mm	± 8 mm	± 20'	± 8 mm				

1 2 3 4 5 6 7 8 9 10 11 12