

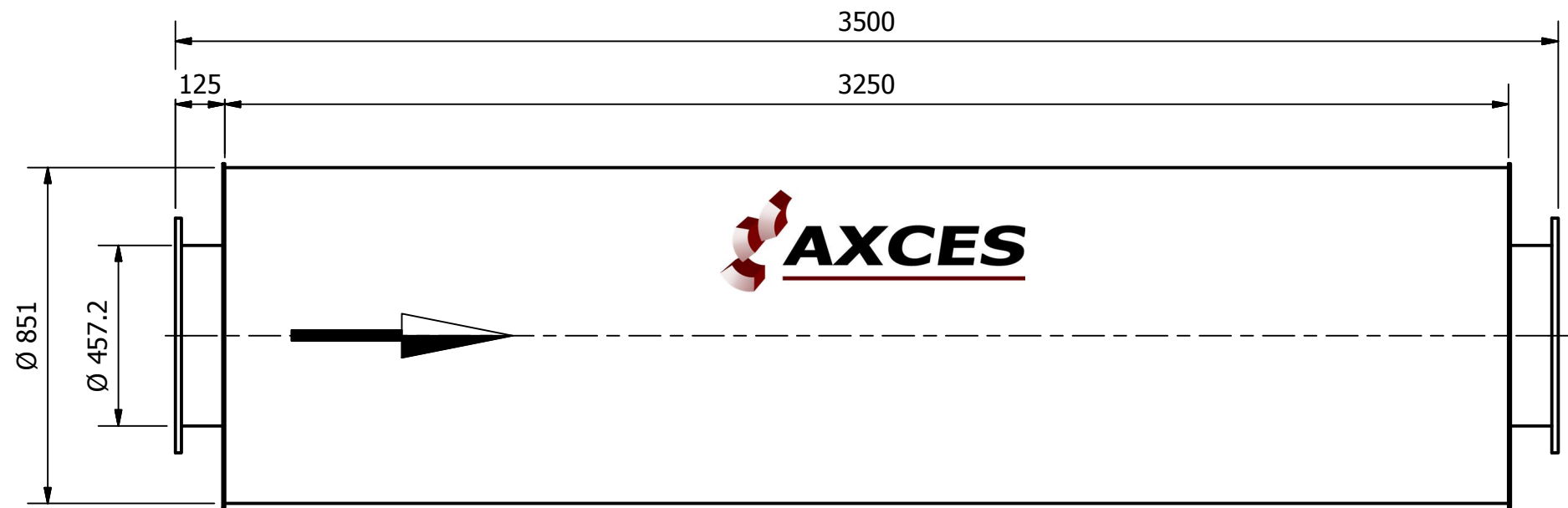

12 11 10 9 8 7 6 5 4 3 2 1

H
G
F
E
D
C
B
A

H
G
F
E
D
C
B
A

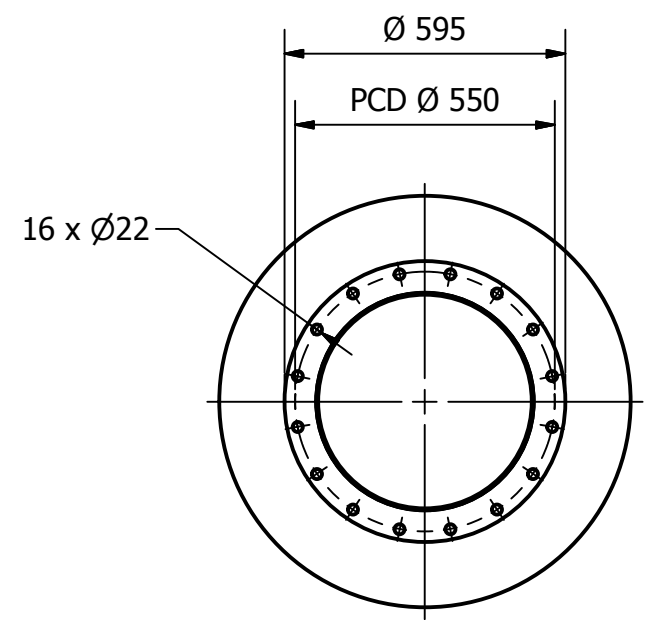

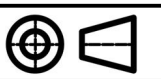
MATERIAL MILD STEEL S235JR							
FLANGES DIN 2573 PN 6				MOD	DESCRIPTION	DRAWN	DATE
COATING SILICONE PAINT - THERMORESISTANT UP TO 600C, SILVER					Axces B.V. Ondernemersweg 12 4691 SL Tholen The Netherlands www.axces.com +31 (0) 166 603 285	ALL RIGHTS RESERVED THIS DRAWING SHALL NOT BE REPRODUCED WITHOUT THE PRIOR PERMISSION OF AXCES B.V.	
WELDING QUALITY ACC. TO 5817 CLASS C						NUMBER OF SHEETS 1	DATE 2013-10-25
TOLERANCES ACC. TO EN-ISO 13920 CLASS B,F						ARTICLE NUMBER 130100000180	
DIMENSIONS	LENGTH	ANGLE	STRAIGHTNESS FLATNESS PARALLELSM	TITLE EXHAUST SILENCER	DRAWING NUMBER 181113/ABS/18	DRAWN ES	
400 mm	+/-2 mm	+/-45'	+/-1,5 mm	TYPE ABS-18" (NB450)	SPARK ARRESTOR NO	DAMPING 20-25 db(A)	
1000 mm	+/-3 mm	+/-30'	+/-3 mm	PROJECTION 	WEIGHT 434 Kg	SCALE 1 / 16	FORMAT A3
2000 mm	+/-4 mm	+/-0,2'	+/-4,5 mm				
4000 mm	+/-6 mm	+/-0,2'	+/-6 mm				
>4000 mm	+/-8 mm	+/-0,2'	+/-8 mm				

12 11 10 9 8 7 6 5 4 3 2 1