

AXCES EXHAUST SYSTEMS



**PRODUCTION
FACILITY**



AXCES

IT'S TIME TO BREAK THE SILENCE ON AXCES

AXCES consists of a group of companies that provide fully-integrated exhaust systems for combustion engines with exhaust silencers as its core-business. Anything installed after the outlet connection of a diesel engine, AXCES delivers. Fully customized to individual ships, propulsion systems or industrial machines.

Specializing in the whole process of design, engineering, manufacturing and supply AXCES offers total exhaust system supply solutions. Relatively basic solutions can be found in its wide range of standard products. AXCES is also the technical and acoustical partner that meets the most challenging noise requirements and specific silencer configurations against minimum back pressure results. AXCES meets your needs with a clear focus on output, efficiency and reliability.

ACOUSTICAL XCELLENCE IN COMPETENT EXHAUST SYSTEMS

AXCES represents: Acoustical Xcellence in Competent Exhaust Systems. Added value is offered by translating the results of extensive scientific research into practical, cost and time saving solutions. Combining intelligence with clearness. It is a philosophy that is proven to be very successful. In a few years time literally thousands of exhaust silencers have been installed both in inland and sea-going vessels, operating daily all over the world.

Within AXCES, high-level scientists, team up, with field-experts to develop exhaust silencers and complete exhaust gas system for diesel engines that help our clients outperform competition.

FULLY-INTEGRATED EXHAUST SYSTEMS

AXCES' working field is defined within the framework regarding everything installed after the exhaust outlet of a combustion engine. Delivery of Fully-Integrated Exhaust Systems customized to the individual ship, is our key.

DESIGN AXCES is guaranteed to meet any noise requirement with tailor-made silencer solutions. With strong expertise both in acoustics and physics, AXCES specializes in custom engineering.

MANUFACTURING AXCES' knowledge centre, sales and distribution is based in the Netherlands. AXCES production in Poland produces top quality solutions at a very competitive price.

SUPPLY AXCES can provide you with everything you need. AXCES is able to deliver most common used accessories within 24 hours. Every part or system comes with full-service and full technical support.



INDUSTRIES

SHIPPING

AXCES delivers worldwide and in many industries, but is specialized in the shipping industry.

ENGINE POWER

AXCES engineers deliver ideal exhaust system for a wide range of energy systems.

ENERGY SYSTEMS

AXCES is leading the way when it comes to exhaust solutions. From basic parts that keep temporary power supplies running to essential parts for safe, efficient and clean generators.

AUTOMOTIVE

AXCES specializes in exhaust systems for really heavy-duty machinery that has to keep going, no matter what.

WHAT WE DO

In cooperation with AXCES Industrial Exhaust Systems creates group, which design and prepare calculations of complete exhaust systems, thanks that we are able to accommodate our products to Your requirements. AXCES Industrial Exhaust Systems during 11 years of activity achieve esteem on world market.

Our products hit on Polish and World markets. We lead cooperation with companies from Holland, Germany, Denmark, Romania, Serbia, Norway. We realize single orders and serial.

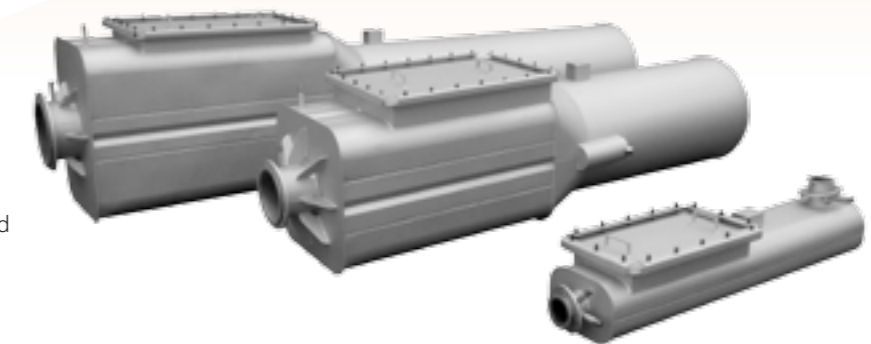

AXCES Production is productive plant dynamically developing, technical back systematically boosting and potential of intellectual employee, that enables to offer of new category of products.

Despite short presence of market (foundation of firm falls to year 2007) we have earned reliance and recognition of trade partners.

PRODUCTION & OPERATIONS MANAGING QUALITY

Achieving high quality is a continue process in our organisation, therefors our production process is properly managed in order to achieve quality standards. Our quality management is concerned with controlling activities with the aim of ensuring that products and services are fit for their purpose and meet the specifications.

QUALITY CONTROL

It includes the process of inspecting products to ensure that they meet the required quality standards method checks the quality of completed products.

The main objective of quality control is to ensure that the business is achieving the standards it sets for itself.

Therefor a quality inspector measure and test every the manufactured product.

Quality control involves setting standards about how much variation is acceptable. The aim is to ensure that a product is manufactured, or a service is provided, to meet the specifications which ensure customer needs are met, where Quality control is achieved through inspection.

ADVANTAGES OF QUALITY CONTROL

With quality control, inspection is intended to prevent faulty products reaching the customer. This approach means that we having specially trained inspectors.

QUALITY ASSURANCE

A definition of quality assurance is: The processes that ensure production quality meets the requirements of customers. This is an approach that aims to achieve quality by organising every process to get the product 'right first time' and prevent mistakes ever happening. This is also known as a 'zero defect' approach. During the process there is also emphasis on 'self-checking', which as a result has its advantage for our clients in:

- ✓ **Costs are reduced because there is less wastage and re-working of faulty products as the product is checked at every stage**
- ✓ **Higher workers' motivation as our employers have more ownership and recognition for their work**

Total quality management (TQM) is a specific approach to quality assurance that aims to develop a quality culture throughout the firm. In TQM, organisations consist of 'quality chains' in which each person or team treats the receiver of their work as if they were an external customer and adopts a target of 'right first time' or zero defects.

QUALITY CONTROL AND QUALITY ASSURANCE HAVE DIRECT ADVANTAGES

- ✓ **Active over the long-term process**
- ✓ **Focus on processes and outputs**
- ✓ **Achieved by improving production processes and inspection targeted both on the production activities and the whole organisation**
- ✓ **Emphasises both to the customer and required standards**
- ✓ **Quality is 'built' into the product and defects are inspected out**

QUALITY CONTROL

It includes the process of inspecting products to ensure that they meet the required quality standards method checks the quality of completed products.

The main objective of quality control is to ensure that the business is achieving the standards it sets for itself.

AXCES CAPACITY

Quality assurance

- ISO 9001:2008
- EN ISO 3834
- EN 1090
- Stacks :Certified EN 13084-7

Welding approvals

- Group 1.1, 1.2 (Mild steel)
- Group 1.1 (16Mo3)
- Group 5.1 (Cr-Mo)
- Group 8, 8.1 (Stainless steel)
- Group 10.1 (Duplex)
- Group 1.2 + 8.1 (Mild steel + Stainless steel)

European welding engineer Quality improvements

- Visual testing
- Dye penetrant testing

Level II + III Inspector



Main Production Equipment

- Workshop hall Dimensions 60m x 40m x 8m
- Roller sheet metal machines
- Asymetrical Plate Roll Machine
- Gas-plasma burning machine (CNC table dimensions 2 x 6 m)
- Shot blasting room
- Special-purpose equipment

PRODUCTION HALL



The Axces production hall measures 60m x 40m x 8m and is equipped with the best tools and technology.

AXCES ONLINE ACCESSORIES WEBSHOP

You can find all of our products in the "Complete Exhaust System and Emission Technologies Webshop". This online facility gives AXCES' clients direct access to more than 2.500 parts related to the exhaust gas system. Fast delivery from large stock.

COMPENSATORS • FLEXIBLE HOSES • ROOF TRANSITS • WALL TRANSITS • SUPPORTING POINTS



RAIN CAPS • MOUNTING SETS • FLANGES • GASKETS • NUTS AND BOLTS • COATINGS



STEEL TUBES • THIN-WALLED TUBES • THIN WALL INSULATED SYSTEMS • INSULATION



WET EXHAUST SYSTEMS • THIN WALL MODULAR SYSTEMS • MEASURING INSTRUMENTS

AXCES PRODUCT RANGE

DRY EXHAUST SILENCERS

WET EXHAUST SYSTEMS

EMISSION - CATALYSTS

EMISSION - SCRUBBERS

INDUSTRIAL STACKS

PRODUCTION FACILITY

PRODUCT CATALOGUE



VISIT OUR ONE-STOP-SHOP WEBSITE

- ✓ Huge selection from small parts to complete exhaust systems
- ✓ Fast delivery
- ✓ top quality solutions at very competitive prices
- ✓ Every part with full-service and full technical support



WWW.SHOP.AXCES.COM



AXCES EXHAUST SYSTEMS



THE AXCES GROUP

The Axces Group designs and manufactures industrial exhaust systems, silencers and chimneys including flue gas cleaning systems as well as acoustic enclosures, steel structures and steel products.

AXCES B.V.

Ondernemersweg 12
4691 SL Tholen
The Netherlands

+31(0)166 603 285
info@axces.com
www.axces.com

Visiting address:
Langesteijn 134
3342 LH Hendrik-Ido-Ambacht The Netherlands

Axces BV includes: Axces Wet Exhaust Systems, Axces Emission Technology, Axces Industrial Stacks, Axces Exhaust Systems

AXCES INDUSTRIAL STACKS B.V.

Visiting address:
Veersedijk 59
3341 LL Hendrik Ido Ambacht
The Netherlands

+31 (0)786 459 822
info@axces.com
www.axces.com

AXCES STEAM AND FLOW CONTROL B.V.

Visiting address:
Langesteijn 134
3342 LH Hendrik-Ido-Ambacht
The Netherlands

+31(0)172 619 246
sales@axces.com
www.steam.axces.com

AXCES EMISSION TECHNOLOGY

Ondernemersweg 12
4691 SL Tholen
The Netherlands

+31(0)166 603 285
info@axces.com
www.axces.com

Visiting address:
Langesteijn 134
3342 LH Hendrik-Ido-Ambacht
The Netherlands

AXCES Production

Młyn 16B
37-550 Radymno
Poland

+48(0)603 676 903
axces@axces.pl
www.axces.pl

AXCES Asia (Singapore)

No. 7, Toh Guan Road East #07-07
Alpha Ind. Building, Singapore

+65 6569-0570
info@axces.sg
www.axces.com

